

铲钻

侧固式铲钻

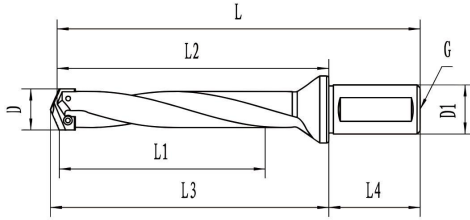

00系列 (φ13.0-φ17.5)

型号	L1	L2	L3	L	D1	L4	G	螺丝	扳手
SD00S-23-XP20	23	47.6	50.4	97.6	20	50	1/8	M2.5*6	T8
SD00S-35-XP20	35	63.5	66.3	113.5	20	50	1/8	M2.5*6	T8
SD00H-64-XP20	64	92.1	94.9	142.1	20	50	1/8	M2.5*6	T8
SD00H-114-XP20	114	142.9	145.7	192.9	20	50	1/8	M2.5*6	T8
SD00H-178-XP20	178	206.4	209.1	256.4	20	50	1/8	M2.5*6	T8
SD00S-240-XP20	240	268.6	271.3	318.6	20	50	1/8	M2.5*6	T8
SD00S-295-XP20	295	323.9	326.7	373.9	20	50	1/8	M2.5*6	T8
SD00S-387-XP20	387	416	418.8	466	20	50	1/8	M2.5*6	T8

05系列 (φ15.5-φ17.5)

型号	L1	L2	L3	L	D1	L4	G	螺丝	扳手
SD05S-23-XP20	23	47.6	50.4	97.6	20	50	1/8	M2.5*6	T8
SD05S-35-XP20	35	63.5	66.3	113.5	20	50	1/8	M2.5*6	T8
SD05H-64-XP20	64	92.1	94.9	142.1	20	50	1/8	M2.5*6	T8
SD05H-114-XP20	114	142.9	145.7	192.9	20	50	1/8	M2.5*6	T8
SD05H-178-XP20	178	206.4	209.1	256.4	20	50	1/8	M2.5*6	T8
SD05S-240-XP20	240	268.6	271.3	318.6	20	50	1/8	M2.5*6	T8
SD05S-295-XP20	295	323.9	326.7	373.9	20	50	1/8	M2.5*6	T8
SD05S-387-XP20	387	416	418.8	466	20	50	1/8	M2.5*6	T8

10系列 (φ17.6-φ24.4)

型号	L1	L2	L3	L	D1	L4	G	螺丝	扳手
SD10S-48-XP25	48	75.8	79.4	131.8	25	56	1/8	M3*8	T8
SD10S-67-XP25	67	107.2	110.7	163.1	25	56	1/8	M3*8	T8
SD10H-118-XP25	118	154.8	158.4	210.8	25	56	1/8	M3*8	T8
SD10H-168-XP25	168	205.6	209.2	261.6	25	56	1/8	M3*8	T8
SD10H-218-XP25	218	255.3	258.9	311.3	25	56	1/8	M3*8	T8
SD10H-270-XP25	270	307.2	310.8	363.2	25	56	1/8	M3*8	T8
SD10S-365-XP25	365	402.2	405.8	458.2	25	56	1/8	M3*8	T8
SD10S-457-XP25	457	494.5	498.1	550.5	25	56	1/8	M3*8	T8
SD10S-569-XP25	569	602.5	606.1	658.5	25	56	1/8	M3*8	T8

15系列 (φ22.0-φ24.4)

型号	L1	L2	L3	L	D1	L4	G	螺丝	扳手
SD15S-57-XP25	57	88.5	92.1	144.5	25	56	1/8	M3*8	T8
SD15S-67-XP25	67	107.2	110.7	163.1	25	56	1/8	M3*8	T8
SD15H-118-XP25	118	154.8	158.4	210.8	25	56	1/8	M3*8	T8
SD15H-168-XP25	168	205.6	209.2	261.6	25	56	1/8	M3*8	T8
SD15H-218-XP25	218	255.3	258.9	311.3	25	56	1/8	M3*8	T8
SD15H-270-XP25	270	307.2	310.8	363.2	25	56	1/8	M3*8	T8
SD15S-365-XP25	365	402.2	405.8	458.2	25	56	1/8	M3*8	T8
SD15S-457-XP25	457	494.5	498.1	550.5	25	56	1/8	M3*8	T8
SD15S-569-XP25	569	602.5	606.1	658.5	25	56	1/8	M3*8	T8

20系列 (φ24.5-φ35.0)

型号	L1	L2	L3	L	D1	L4	G	螺丝	扳手
SD20S-57-XP32	57	88.5	92.1	148.5	32	60	1/4	M3.5*10	T15
SD20S-86-XP32	86	128.6	132.2	188.6	32	60	1/4	M3.5*10	T15
SD20H-137-XP32	137	179.4	183	239.4	32	60	1/4	M3.5*10	T15
SD20H-187-XP32	187	230.2	233.8	290.2	32	60	1/4	M3.5*10	T15
SD20H-237-XP32	237	279.9	283.5	339.9	32	60	1/4	M3.5*10	T15
SD20H-289-XP32	289	331.8	335.4	391.8	32	60	1/4	M3.5*10	T15
SD20H-400-XP32	400	442.8	446.4	502.8	32	60	1/4	M3.5*10	T15
SD20S-400-XP32	400	442.8	446.4	502.8	32	60	1/4	M3.5*10	T15
SD20S-511-XP32	551	554.1	557.7	614.1	32	60	1/4	M3.5*10	T15
SD20S-692-XP32	692	735.1	738.7	795.1	32	60	1/4	M3.5*10	T15

25系列 (φ30.0-φ35.0)

型号	L1	L2	L3	L	D1	L4	G	螺丝	扳手
SD25S-92-XP32	92	123.4	127	183.4	32	60	1/4	M3.5*10	T15
SD25S-86-XP32	86	128.6	132.2	188.6	32	60	1/4	M3.5*10	T15
SD25H-137-XP32	137	179.4	183	239.4	32	60	1/4	M3.5*10	T15
SD25H-187-XP32	187	230.2	233.8	290.2	32	60	1/4	M3.5*10	T15
SD25H-237-XP32	237	279.9	283.5	339.9	32	60	1/4	M3.5*10	T15
SD25H-289-XP32	289	331.8	335.4	391.8	32	60	1/4	M3.5*10	T15
SD25H-400-XP32	400	442.8	446.4	502.8	32	60	1/4	M3.5*10	T15
SD25S-400-XP32	400	442.8	446.4	502.8	32	60	1/4	M3.5*10	T15
SD25S-511-XP32	511	554.1	557.7	614.1	32	60	1/4	M3.5*10	T15
SD25S-692-XP32	692	735.1	738.7	795.1	32	60	1/4	M3.5*10	T15

30系列 (φ35.1-φ47.9)

型号	L1	L2	L3	L	D1	L4	G	螺丝	扳手
SD30S-76-XP40	76	125	129.8	195	40	70	1/4	M5*10	T20
SD30S-121-XP40	121	173	177.8	243	40	70	1/4	M5*10	T20
SD30H-165-XP40	165	217.5	222.3	287.5	40	70	1/4	M5*10	T20
SD30H-210-XP40	210	261.9	266.7	331.9	40	70	1/4	M5*10	T20
SD30H-260-XP40	260	312.3	317.1	382.3	40	70	1/4	M5*10	T20
SD30S-349-XP40	349	401.6	406.4	471.6	40	70	1/4	M5*10	T20
SD30H-349-XP40	349	401.6	406.4	471.6	40	70	1/4	M5*10	T20
SD30S-559-XP40	559	611.1	615.9	681.1	40	70	1/4	M5*10	T20
SD30S-787-XP40	787	839.7	844.5	909.7	40	70	1/4	M5*10	T20

35系列 (φ42.0-φ47.9)

型号	L1	L2	L3	L	D1	L4	G	螺丝	扳手
SD35S-76-XP40	76	125	129.8	195	40	70	1/4	M5*10	T20
SD35S-121-XP40	121	173	177.8	243	40	70	1/4	M5*10	T20
SD35H-165-XP40	165	217.5	222.3	287.5	40	70	1/4	M5*10	T20
SD35H-210-XP40	210	261.9	266.7	331.9	40	70	1/4	M5*10	T20
SD35H-260-XP40	260	312.3	317.1	382.3	40	70	1/4	M5*10	T20
SD35S-349-XP40	349	401.6	406.4	471.6	40	70	1/4	M5*10	T20
SD35H-349-XP40	349	401.6	406.4	471.6	40	70	1/4	M5*10	T20
SD35S-559-XP40	559	611.1	615.9	681.1	40	70	1/4	M5*10	T20
SD35S-787-XP40	787	839.7	844.5	909.7	40	70	1/4	M5*10	T20

铲钻

侧固式铲钻-莫氏铲钻

40系列 (φ48.0-φ65.28)

型号	L1	L2	L3	L	D1	L4	G	螺丝	扳手
SD40S-130-XP40	130	179.4	184.2	249.4	40	70	1/4	M5*15	T20
SD40H-232-XP40	232	281	285.8	351	40	70	1/4	M5*15	T20
SD40S-350-XP40	350	399.2	404	469.2	40	70	1/4	M5*15	T20
SD40H-350-XP40	350	399.2	404	469.2	40	70	1/4	M5*15	T20
SD40S-422-XP40	422	471.5	476.3	541.5	40	70	1/4	M5*15	T20
SD40H-422-XP40	422	471.5	476.3	541.5	40	70	1/4	M5*15	T20
SD40S-525-XP40	525	574.2	579	644.2	40	70	1/4	M5*15	T20
SD40S-625-XP40	625	674.7	679.5	744.7	40	70	1/4	M5*15	T20
SD40S-879-XP40	879	928.7	933.5	998.7	40	70	1/4	M5*15	T20

45系列 (φ56.0-φ65.28)

型号	L1	L2	L3	L	D1	L4	G	螺丝	扳手
SD45S-130-XP40	130	179.4	184.2	249.4	40	70	1/4	M5*15	T20
SD45H-232-XP40	232	281	285.8	351	40	70	1/4	M5*15	T20
SD45S-350-XP40	350	399.2	404	469.2	40	70	1/4	M5*15	T20
SD45H-350-XP40	350	399.2	404	469.2	40	70	1/4	M5*15	T20
SD45H-422-XP40	422	471.5	476.3	541.5	40	70	1/4	M5*15	T20
SD45S-422-XP40	422	471.5	476.3	541.5	40	70	1/4	M5*15	T20
SD45S-525-XP40	525	574.2	579	644.2	40	70	1/4	M5*15	T20
SD45S-625-XP40	625	674.7	679.5	744.7	40	70	1/4	M5*15	T20
SD45S-879-XP40	879	928.7	933.5	998.7	40	70	1/4	M5*15	T20

50系列 (φ65.3-φ89.08)

型号	L1	L2	L3	L	D1	L4	G	螺丝	扳手
SD50S-171-XP50	171	235	240	315	50	80	1/2	M6*15	T25
SD50S-350-XP50	350	414	419	494	50	80	1/2	M6*15	T25
SD50S-660-XP50	660	724	729	804	50	80	1/2	M6*15	T25

70系列 (φ89.1-φ114.48)

型号	L1	L2	L3	L	D1	L4	G	螺丝	扳手
SD70S-200-XP50	200	275	280	355	50	80	1/2	M6*15	T25
SD70S-400-XP50	400	475	480	555	50	80	1/2	M6*15	T25
SD70S-800-XP50	800	875	880	955	50	80	1/2	M6*15	T25

型号命名规则:

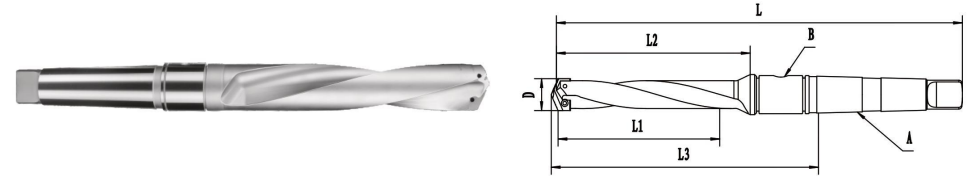
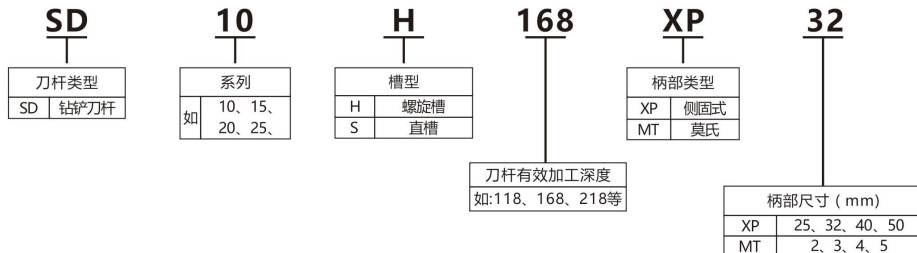

00系列 (φ13.0-φ17.5)

型号	L1	L2	L3	L	A	B	外罩	螺丝	扳手
SD00S-35-MT2	35	55.5	95.4	167.3	MT2	1/16	RK-MT2R	M2.5*6	T8
SD00H-63-MT2	63	84.1	124	195.9	MT2	1/16	RK-MT2R	M2.5*6	T8
SD00H-114-MT2	114	135	174.8	246.7	MT2	1/16	RK-MT2R	M2.5*6	T8
SD00H-178-MT2	178	198.5	238.3	310.2	MT2	1/16	RK-MT2R	M2.5*6	T8

05系列 (φ15.5-φ17.5)

型号	L1	L2	L3	L	A	B	外罩	螺丝	扳手
SD05S-35-MT2	35	55.5	95.4	167.3	MT2	1/16	RK-MT2R	M2.5*6	T8
SD05H-63-MT2	63	84.1	124	195.9	MT2	1/16	RK-MT2R	M2.5*6	T8
SD05H-114-MT2	114	135	174.8	246.7	MT2	1/16	RK-MT2R	M2.5*6	T8
SD05H-178-MT2	178	198.5	238.3	310.2	MT2	1/16	RK-MT2R	M2.5*6	T8

10系列 (φ17.6-φ24.4)

型号	L1	L2	L3	L	A	B	外罩	螺丝	扳手
SD10S-70-MT3	70	98.4	149	239	MT3	1/8	RK-MT3R	M3*8	T8
SD10H-121-MT3	121	149.2	199.8	289.8	MT3	1/8	RK-MT3R	M3*8	T8
SD10H-171-MT3	171	200	250.6	340.7	MT3	1/8	RK-MT3R	M3*8	T8
SD10H-222-MT3	222	250.5	301.1	391.2	MT3	1/8	RK-MT3R	M3*8	T8
SD10H-273-MT3	273	301.6	352.2	442.3	MT3	1/8	RK-MT3R	M3*8	T8

15系列 (φ22.0-φ24.4)

型号	L1	L2	L3	L	A	B	外罩	螺丝	扳手
SD15S-70-MT3	70	98.4	149	239	MT3	1/8	RK-MT3R	M3*8	T8
SD15H-121-MT3	121	149.2	199.8	289.8	MT3	1/8	RK-MT3R	M3*8	T8
SD15H-171-MT3	171	200	250.6	340.7	MT3	1/8	RK-MT3R	M3*8	T8
SD15H-222-MT3	222	250.5	301.1	391.2	MT3	1/8	RK-MT3R	M3*8	T8
SD15H-273-MT3	273	301.6	352.2	442.3	MT3	1/8	RK-MT3R	M3*8	T8

20系列 (φ24.5-φ35.0)

型号	L1	L2	L3	L	A	B	外罩	螺丝	扳手
SD20S-86-MT4	86	114.3	172.9	286.3	MT4	1/4	RK-MT4R	M3.5*10	T15
SD20H-137-MT4	137	165.1	223.7	337.1	MT4	1/4	RK-MT4R	M3.5*10	T15
SD20H-187-MT4	187	215.9	274.5	387.9	MT4	1/4	RK-MT4R	M3.5*10	T15
SD20H-237-MT4	237	265.6	324.2	437.6	MT4	1/4	RK-MT4R	M3.5*10	T15
SD20H-289-MT4	289	317.5	376.1	489.5	MT4	1/4	RK-MT4R	M3.5*10	T15
SD20S-400-MT4	400	428.5	487.1	600	MT4	1/4	RK-MT4R	M3.5*10	T15
SD20H-400-MT4	400	428.5	487.1	600	MT4	1/4	RK-MT4R	M3.5*10	T15

铲钻

莫氏铲钻

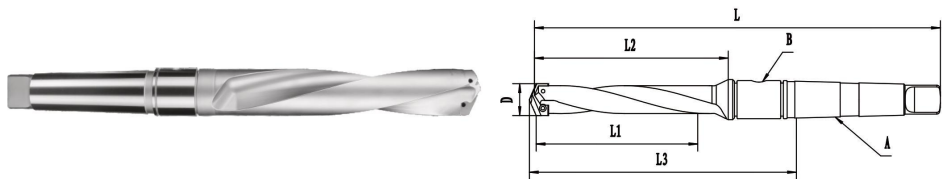

25系列 (φ30.0-φ35.0)

型号	L1	L2	L3	L	A	B	外罩	螺丝	扳手
SD25S-86-MT4	86	114.3	172.9	286.3	MT4	1/4	RK-MT4R	M3.5*10	T15
SD25H-137-MT4	137	165.1	223.7	337.1	MT4	1/4	RK-MT4R	M3.5*10	T15
SD25H-187-MT4	187	215.9	274.5	387.9	MT4	1/4	RK-MT4R	M3.5*10	T15
SD25H-237-MT4	237	265.6	324.2	437.6	MT4	1/4	RK-MT4R	M3.5*10	T15
SD25H-289-MT4	289	317.5	376.1	489.5	MT4	1/4	RK-MT4R	M3.5*10	T15
SD25S-400-MT4	400	428.5	487.1	600	MT4	1/4	RK-MT4R	M3.5*10	T15
SD25H-400-MT4	400	428.5	487.1	600	MT4	1/4	RK-MT4R	M3.5*10	T15

30系列 (φ35.1-φ47.9)

型号	L1	L2	L3	L	A	B	外罩	螺丝	扳手
SD30S-121-MT4	121	152.4	211.7	324.4	MT4	1/4	RK-MT4R	M5*10	T20
SD30H-165-MT4	165	196.9	256.2	368.9	MT4	1/4	RK-MT4R	M5*10	T20
SD30H-209-MT4	209	241.3	300.6	413.3	MT4	1/4	RK-MT4R	M5*10	T20
SD30H-260-MT4	260	291.8	351.1	463.8	MT4	1/4	RK-MT4R	M5*10	T20
SD30H-349-MT4	349	381	440.3	553	MT4	1/4	RK-MT4R	M5*10	T20
SD30S-349-MT4	349	381	440.3	553	MT4	1/4	RK-MT4R	M5*10	T20
SD30S-559-MT4	559	590.6	649.9	762.5	MT4	1/4	RK-MT4R	M5*10	T20
SD30S-787-MT4	787	819.2	878.5	991.1	MT4	1/4	RK-MT4R	M5*10	T20

35系列 (φ42.0-φ47.9)

型号	L1	L2	L3	L	A	B	外罩	螺丝	扳手
SD35S-121-MT4	121	152.4	211.7	324.4	MT4	1/4	RK-MT4R	M5*10	T20
SD35H-165-MT4	165	196.9	256.2	368.9	MT4	1/4	RK-MT4R	M5*10	T20
SD35H-209-MT4	209	241.3	300.6	413.3	MT4	1/4	RK-MT4R	M5*10	T20
SD30H-260-MT4	260	291.8	351.1	463.8	MT4	1/4	RK-MT4R	M5*10	T20
SD35H-349-MT4	349	381	440.3	553	MT4	1/4	RK-MT4R	M5*10	T20
SD35S-349-MT4	349	381	440.3	553	MT4	1/4	RK-MT4R	M5*10	T20
SD35S-559-MT4	559	590.6	649.9	762.5	MT4	1/4	RK-MT4R	M5*10	T20
SD35S-787-MT4	787	819.2	878.5	991.1	MT4	1/4	RK-MT4R	M5*10	T20

40系列 (φ48.0-φ65.28)

型号	L1	L2	L3	L	A	B	外罩	螺丝	扳手
SD40S-130-MT5	130	165.1	225	369.4	MT5	1/4	RK-MT5R1	M5*15	T20
SD40H-232-MT5	232	266.7	326.6	471	MT5	1/4	RK-MT5R1	M5*15	T20
SD40S-350-MT5	350	384.9	444.8	589.2	MT5	1/4	RK-MT5R1	M5*15	T20
SD40H-350-MT5	350	384.9	444.8	589.2	MT5	1/4	RK-MT5R1	M5*15	T20
SD40H-422-MT5	422	457.2	517.1	661.5	MT5	1/4	RK-MT5R1	M5*15	T20
SD40S-422-MT5	422	457.2	517.1	661.5	MT5	1/4	RK-MT5R1	M5*15	T20
SD40S-625-MT5	625	660.4	720.3	864.7	MT5	1/4	RK-MT5R1	M5*15	T20
SD40S-879-MT5	879	914.4	974.3	1119	MT5	1/4	RK-MT5R1	M5*15	T20

45系列 (φ56.0-φ65.28)

型号	L1	L2	L3	L	A	B	外罩	螺丝	扳手
SD45S-130-MT5	130	165.1	225	369.4	MT5	1/4	RK-MT5R1	M5*15	T20
SD45H-232-MT5	232	266.7	326.6	471	MT5	1/4	RK-MT5R1	M5*15	T20
SD45S-350-MT5	350	384.9	444.8	589.2	MT5	1/4	RK-MT5R1	M5*15	T20
SD45H-350-MT5	350	384.9	444.8	589.2	MT5	1/4	RK-MT5R1	M5*15	T20
SD45H-422-MT5	422	457.2	517.1	661.5	MT5	1/4	RK-MT5R1	M5*15	T20
SD45S-422-MT5	422	457.2	517.1	661.5	MT5	1/4	RK-MT5R1	M5*15	T20
SD45S-625-MT5	625	660.4	720.3	864.7	MT5	1/4	RK-MT5R1	M5*15	T20
SD45S-879-MT5	879	914.4	974.3	1119	MT5	1/4	RK-MT5R1	M5*15	T20

50系列 (φ65.3-φ89.08)

型号	L1	L2	L3	L	A	B	外罩	螺丝	扳手
SD50S-171-MT5	171	215.9	287.3	430.2	MT5	1/2	RK-MT5R2	M6*15	T25
SD50H-273-MT5	273	317.5	388.9	531.8	MT5	1/2	RK-MT5R2	M6*15	T25
SD50S-464-MT5	464	508	579.4	722.3	MT5	1/2	RK-MT5R2	M6*15	T25
SD50S-660-MT5	660	704.8	776.2	919.1	MT5	1/2	RK-MT5R2	M6*15	T25
SD50S-889-MT5	889	933.4	1005	1148	MT5	1/2	RK-MT5R2	M6*15	T25

70系列 (φ89.1-φ114.48)

型号	L1	L2	L3	L	A	B	外罩	螺丝	扳手
SD70S-171-MT5	171	225.4	296.8	439.7	MT5	1/2	RK-MT5R2	M6*15	T25
SD70H-273-MT5	273	327	398.5	541.3	MT5	1/2	RK-MT5R2	M6*15	T25
SD70S-556-MT5	556	609.6	681.1	823.9	MT5	1/2	RK-MT5R2	M6*15	T25
SD70S-685-MT5	685	739.7	811.2	954	MT5	1/2	RK-MT5R2	M6*15	T25
SD70S-939-MT5	939	993.7	1065.2	1208	MT5	1/2	RK-MT5R2	M6*15	T25

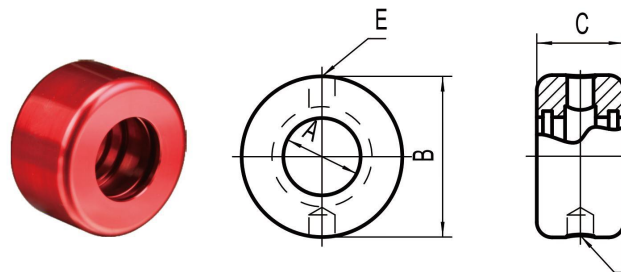

铲钻冷却环

型号	内径(A)	外径(B)	厚度(C)	挡杆螺纹(D)	冷却嘴螺纹(D)
RK-MT2R	19.4	49	22.5	M8X1.25	1/8"
RK-MT3R	25.5	53	30	M8X1.25	1/8"
RK-MT4R	32.5	63	36	M10X1.5	1/4"
RK-MT5R1	48.5	76	36	M10X1.5	1/4"
RK-MT5R2	60.1	95.3	44.5	M12X1.75	1/2"

铲钻刀片

铲钻介绍:

- 一、铲钻是传统麻花钻的升级换代产品，可应用于数控设备及各种传统设备上，如立钻、摇臂钻等。
- 二、加工不同材质的工件时选择不同材质的铲钻刀片进行加工，铲钻刀片材质分为硬质合金、粉末高速钢和含钴高速钢三种材质，同直径三种材质刀片均可安装于同一支铲钻刀杆上，大大降低客户在刀杆上购买成本。
- 三、立钻、摇臂钻上推荐使用高速钢和粉末高速钢刀片，不建议使用硬质合金刀片，机床转速低，刚性差，间隙大，容易造成硬质合金刀片崩刃。
- 四、所有铲钻刀杆均有中心出水孔孔，推荐尽量使用高压内冷却液，这样会大大地延长刀片的使用寿命，也更加有利于排屑。
- 五、所有铲钻刀片均有设计断屑槽，加工出来的铁屑均为小碎屑，相比传统麻花钻加工出来的长屑，小碎屑更加容易排屑，且不需回退断屑，可一打到底，使加工的时间缩短，提升加工效率。
- 六、铲钻刀片具有自定心功能，双刃对称均匀受力，所以适合加工深孔。

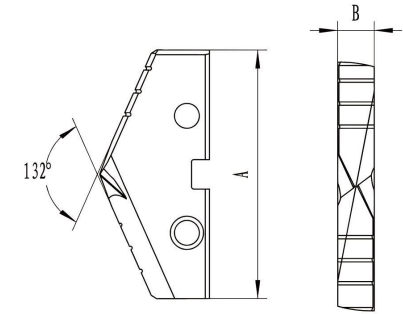
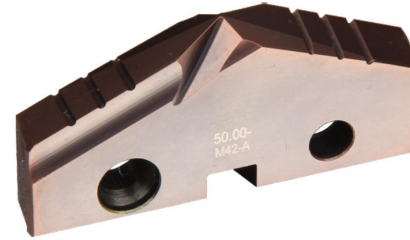

铲钻加工参数计算:

高速钢铲钻刀片和粉末高速钢铲钻刀片线速度为20-40米/秒左右，硬质合金线速度为60-80米/秒左右。

计算转速公式为 $S = Vc * 1000 / 3.14 / Dc$ (S为转速, Vc为线速度, Dc为刀片直径)

进给计算公式为 $Vf = Fr * S$ (Vf为进给, Fr为每转进给, S为转速) 铲钻刀片每转进给能达到每转0.2-0.6mm。

孔加工时间公式为 $Tc = H / Vf * 60$ (Tc为加工时间, H为孔深, Vf为进给)

加工转速、进给计算案例:

加工直径20mm, 深度100mm, 选择粉末高速钢刀片, 线速度按40米/秒计算。

$S = 40 * 1000 / 3.14 / 20 \approx 636$ (建议每分钟转速为600-650转左右)

$Vf = 0.2 * 636 \approx 127$ (建议每分钟进给为110-130左右)

$Tc = 100 / 127 * 60 \approx 47$ (加工时间约为50秒左右)

使用过程中转速、进给应按客户的加工环境等因素做调整。如有疑问请至电我司, 我司会针对客户实际情况给出意见。

真实案例展示:

加工20Cr (锻件、表面凹凸不平), HRC25。直径22.7mm, 深度540mm, 斗山卧加, S 400rev/min / Fr 0.1mm/rev (此参数为客户试用时保守参数, 正常使用时加工参数应会适当的提高)。铲钻有效加工深度260mm (11倍径), 加工方式为双头加工。加工误差0.1mm, 轻松穿销子。使用粉末高速钢刀片无涂层, 加工60个孔, 使用寿命达32米。客户原先使用其他公司铲钻误差达5mm以上。

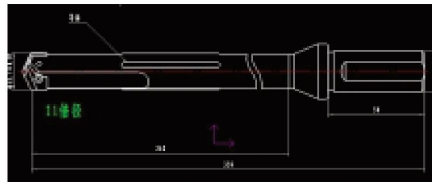

铲钻刀片

直径	厚度	材质			直径	厚度	材质		
		含钴高速钢M42	粉末高速钢S40	硬质合金G12			含钴高速钢M42	粉末高速钢S40	硬质合金G12
13.0	3.18	●	●	○	32.0	4.76	●	●	●
13.5		●	●	○	32.5		●	●	●
14.0		●	●	○	33.0		●	●	●
14.5		●	●	○	33.5		●	●	●
15.0		●	●	○	34.0		●	●	●
15.5		●	●	○	34.5		●	●	●
16.0		●	●	○	35.0		●	●	●
16.5		●	●	○	35.5		●	●	●
17.0		●	●	○	36.0		●	●	●
17.5		●	●	○	36.5		●	●	●
18.0	●	●	●	37.0	●	●	●		
18.5	●	●	●	37.5	●	●	○		
19.0	●	●	●	38.0	●	●	○		
19.5	●	●	●	38.5	●	●	○		
20.0	●	●	●	39.0	●	●	○		
20.5	●	●	●	39.5	●	●	○		
21.0	3.97	●	●	●	40.0	6.35	●	●	○
21.5		●	●	●	41.0		●	●	○
22.0		●	●	●	42.0		●	●	○
22.5		●	●	●	43.0		●	●	○
23.0		●	●	●	44.0		●	●	○
23.5		●	●	●	45.0		●	●	○
24.0		●	●	●	46.0		●	●	○
24.5		●	●	●	47.0		●	●	○
25.0		●	●	●	48.0		●	●	○
25.5		●	●	●	49.0		●	●	○
26.0	●	●	●	50.0	●	●	○		
26.5	●	●	●	51.0	●	●	○		
27.0	●	●	●	52.0	●	●	○		
27.5	●	●	●	53.0	●	●	○		
28.0	4.76	●	●	●	54.0	7.94	●	●	○
28.5		●	●	●	55.0		●	●	○
29.0		●	●	●	56.0		●	●	○
29.5		●	●	●	57.0		●	●	○
30.0		●	●	●	58.0		●	●	○
30.5		●	●	●	59.0		●	●	○
31.0		●	●	●	60.0		●	●	○
31.5		●	●	●					