



Servo Systems



Rail Systems



Balancers



Ergo Assists



Controls



Tables , Carts & Shuttles

▶ Product *Catalog*

KNIGHT

PROVEN INNOVATORS

of Material Handling Systems





▶ **IDEA**

Knight has the ability to transform a concept...



DESIGN ◀

by incorporating State-of-the-Art CAD Systems...



▶ **BUILD**

and using the latest machining, fabrication, and assembly technologies...



REALITY ◀

to solve your ergonomic material handling needs.



▶ **QUALITY**

Knight has achieved the highest Quality Assurance Certifications
ISO 9001:2000, ISO14001:2004 and Ford Q1.

We are committed to Total Customer Satisfaction through
QUALITY, RELIABILITY AND EMPLOYEE INVOLVEMENT

Knight Industries warrants that its products and parts shall meet all applicable specifications, performance requirements, and be free from defects in material and workmanship for one year from the date of invoice. Individual items may have their own warranties. Exclusions include (but not limited to) inadequate training provided by customer regarding the operation and / or maintenance of the tool, misuse, sabotage, maladjustment, or alteration not approved by Knight Industries.

Buyer must submit a claim through the Return Goods Authorization process by contacting Knight Industries Customer Service. All rework is to be done at Knight Industries unless previously agreed to arrangements are made. Buyer is responsible for all associated internal removal and reinstallation costs as well as freight charges to and from Knight Industries.

After substantiation of claim, Seller is only responsible to repair or replace its product, and/or to meet performance requirements per the original stated contract. Seller is not liable for incidental or consequential damages.

<u>Servo Systems</u>	
Servo Hoist	2
Twin Chain	2
Articulating Extension Arm	2
Vertical Arm	3
Vertical Articulating Arm	3
Servo Hoist and Tractor	3
Servo Rack and Pinion Tractor	3
Servo Hoist Accessories	2-3
<u>Rail</u>	
Aluminum Rail	4
Steel Rail	4
Tool Rail	4
Engineered Rail	5
Jib Cranes	5
Rail Accessories	5
<u>Balancers</u>	
Single Cable	8
Single Chain	8
Dual Drum	8
Reeved	8
Tandem	8
Tandem Reeved	8
Pneumatic Controls	9
Balancer Accessories	9
<u>Ergo Assists</u>	
Articulating Arms	10
Extension Arms	10
Path Guided Arms	10
Carriage Arms	10
Vertical Mast Arms	11
Torque Paks	11
Side Mounted Arms	11
Tool Bench Mounted Arms	11
Tool Holders	11
End of Arm Tooling	12
<u>Controls</u>	
Pneumatic Control Handles	14
Electric Control Handles	14
Lever Options	14
<u>Tables, Shuttles and Carts</u>	
Lift Tables	15
Lift and Rotate Tables	15
Low Profile Lift Table	15
Low Profile Lift & Rotate Table	15
Lift & Tilt Tables	15
Cart Lift Tables	15
Tilt Tables	16
Slide-Tilt Tables	16
Corner Tilt Tables	16
Turntables	16
Pull / Tugger Carts	16
Double Scissor Lift Tables	16
Small Footprint Zero Loaders	16
Zero Loaders	16
Operator Platform Lifts	17
Smart Cart	17
Powered Accumulators	17
Non-Powered Accumulators	17
Shuttle Systems	17
Small Footprint Over/Under System	17
Table Accessories	17

Servo Systems

The Knight Servo Systems are Intelligent Assist Devices (IAD) that make lifting and moving loads smarter and more efficient. These innovative systems provide controlled transfer of workloads, including options to allow for various programmed product functionality.

Servo Accessories

Inline Handle

Programmable handle which includes a run-stop button, programmable port and I/O configuration port.

Model# EBA1000 Shown

Dual Speed Handle (DSH)

Comes equipped with the same features of the Standard Inline Handle. Available in a single or two speed configuration. This unit may be mounted on a separate cable.

Model# EBA1010 Shown

Dual Speed Handle without pushbutton

Non-programmable handle that is available in a single or two speed configuration. This unit may be mounted on a separate cable.

Model# EBA9100 Shown

Pancake Handle

Used in conjunction with the Dual Speed Handle when an Inline handle is not a practical solution for the application.

Model# EBA1007 Shown



Servo Hoist

Enables the operator to precisely locate and/or float a load in the "Z" direction using programmable limits. The standard hoist has the lifting capacity of up to 1000lbs[454kg] (Reeved unit). The hoist can travel up to 200' fpm[70mpm].

Model# KSHAEA250-2301 Shown



Servo Hoist Twin Chain

Incorporates the benefits of a Servo System into a twin chain process. The twin chains help control unwieldy or long parts. The standard hoist has the lifting capacity of up to 1000lbs[454kg] (Reeved unit). The hoist can travel up to 200' fpm[70mpm].

Model# KSHTC250-2301 Shown



Servo Hoist Articulating Extension Arm

Servo Hoist mounted on an articulating boom to allow for non-linear reach within a work cell. The standard hoist has the lifting capacity of up to 250lbs [113kg]. The hoist can travel up to 200' fpm[70mpm].

*** 500, 700 and 1000lb arms are application dependent and are considered a special order.*

Model# KSH250-2301 Shown



Servo Hoist Extension Arm "Overhead Mounted"

Incorporates a Servo Hoist within a boom to allow the operator to reach outside the area directly below the rail. The standard hoist has the lifting capacity of up to 250lbs[113kg]. The hoist can travel up to 200' fpm[70mpm].

*** 500, 700 and 1000lb arms are application dependent and are considered a special order.*

Model# KSHEA250-2301 Shown

Servo Hoist Vertical Articulating Arm "Floor Mounted"

A Servo Hoist mounted on an articulating boom to allow for non-linear reach within a work cell. The standard hoist has the lifting capacity of up to 250lbs[113kg]. The hoist can travel up to 200' fpm[70mpm].

*** 500, 700 and 1000lb arms are application dependent and are considered a special order.*

Model# KSHVAA250-2301 Shown



Servo Hoist Vertical Arm "Overhead Mounted"

A Servo Hoist mounted on a vertical aluminum mast to create a steady state condition, eliminating the yarding of a cable or chain. The standard hoist has the lifting capacity of up to 1000lbs [454kg]. The hoist can travel up to 200' fpm[70mpm].

Model# KSHVA250-2301 Shown



Servo Hoist and Tractor

Combines both "X", "Y" and "Z" movements in one handle. The standard hoist has the lifting capacity of up to 1000lbs[1814kg]. The hoist can travel up to 184' fpm[56mpm].

Model# KSHXZ Shown



Servo Rack and Pinion Tractor

Accurately locates a load in the "X" and/or "Y" direction. The standard tractor can move a load of up to 4000lbs[1814kg]. The tractor can travel up to 184' fpm[56mpm].

Model# KST4000 Shown



Servo Accessories

2" Hook

Has an open bend to keep the load inline with the chain. The open bend allows for ease of hitching to load.

Model# EBA1001 Shown



Shackle

Secures fixtures or loads in-line with chain.

Model# EBA1002 Shown



Quick Connect

Allows for fast and easy changes of standard or customized end effectors

Model# EBA1008 Shown



Coil Cable

This cable allows for the use of an In-line handle in a clean and compact package around the chain.

Model# EBA1011-6 Shown



Pendant Cable

This cable configuration allows for the use of the DSH and gives the flexibility of remotely mounting the DSH.

Model# EBA1009-3 Shown



Load Trolley

Attaches servo hoist to Knight 7500 & 4100 Series Rail.

Model# EBA1030 Shown



Rail Systems

Knight Rail Systems are designed with an enclosed trolley track that resists dirt build up for smoother and quieter operation. The weld-free Aluminum Rail Splice Kits (which easily bolt together) eliminates welding in the field. In addition, rails have a load carrying capability up to 3000lbs. Knight offers a wide range of rail options for specific engineering or application requirements.

Overhead Rail Suspension System



Floor Mounted Rail Suspension System



Overhead and Floor Mounted Rail Suspension Systems are available in dual or single bridge configurations.

Aluminum Rails

Knight Overhead Aluminum Enclosed Track Rail System is extruded from high strength aluminum alloy with a load capacity holding up to 3000lbs [1360kg]. The aluminum rail is lightweight and comes in (3) three sizes: 8" [20cm] RAD7500, 4" [10cm] RAD4100, and 2" [5cm] TR2000. Aluminum rail is available in lengths up to 25' [7.62m] without the need for a splice. Aluminum rail is also available in curved sections.



Steel Rails

Knight Overhead Steel Enclosed Track Rail System is ideal for offset and side loading applications with load capacities holding up to 1000lbs [454kg]. The steel rail comes in (3) three sizes: 7" [17.75cm] RSD5700, 5" RSD5500 [12.7cm], and 3" RSD5300 [7.6cm]. Steel rail is available in lengths up to 20' [6m] without the need for a splice.



Tool Rails

Tool Rail is easy to install and set-up on structures such as C-Channel or angle iron. The tool rail is lightweight and comes in (3) three sizes: TR2000, HAD3500 and HAD3000. HAD3000 chambered rail can be used as a fluid power distribution systems for water, air, oil and other non-caustic fluids. The non-corrosive rail serves as a manifold which provides more CFM to the tool when compared to black pipe. The TR2000 is ideal for applications under 550 lbs [249kg] capacity. Allows festooning trolleys and plant utilities to be attached to the main line rail system.





Engineered Round Rail

RAD4700 and RAD6500 Round Rail is ideal for low friction vertical or horizontal linear movement and is capable of handling direct or offset loads as well as high torque applications. This rail is designed to handle heavier loads when compared to traditional linear motion products.



Engineered Linear Rail

LRD9500 Linear Rail is ideal for floor mounted and side mounted low friction horizontal movement, capable of handling direct or offset loads. It has significantly lower maintenance and is a forgiving alternative to the hardened ground rail and bearing block. Binding is significantly reduced due to its flexible tolerances.



Knight Jib Cranes

Jib Cranes are on thrust bearings for smooth 360° rotation. Ideal for short transfer applications. Allows for maximum hoist height on low head room applications. A two component design makes installation and set up simple. Jib lengths are available up to 14ft[4.26m] and can be extended by adding an under hung telescoping rail.

Rail Accessories



End Caps

Serves as a dust cover. Can be used in conjunction with a mid-rail stop to form a redundant stop.

Model# MRAA4804 (left)
MRAA4011 (right) Shown

Shock Absorber

Dampens the impact force of the load trolley striking the end cap.

Model# MRAA4805 Shown



Hose Management Kit

Each kit includes a filter/regulator, brackets, fittings and pressure gauge for festooned or coiled hose.

Model# MRMS4065 Shown

End of Travel Switch

Provides the availability to mount an end of travel switch to a rail system. Trolley mounted actuator has a bypass feature.

Model# MRAA4228 Shown



Bridge Brace

Used to secure parallel rails at specific distances. Spans greater than 15ft [4.5m] require two braces.

Model# MRAA4205-8 Shown

Bridge Stop Assembly

Prevents bridges from colliding into one another.

Model# MRAA4926 Shown



(Rail Accessories Continued)



Hose Trolley

Carries festooned hose used in hose management kits.

Model# MRMA4019 Shown



Rail Brake

Pneumatic stop allows the operator to park a bridge or arm on the rail.

Model# MRTA7795 Shown



Cable Saddle

Adapts standard hose trolley to accommodate up to 2" [5cm] electrical cable.



Inspection Gate

Allows for the maintenance and inspection of a trolley without disassembling the system.

Model# MRAA7558 Shown



Rail Splice

Joins runways or monorails. A hanger must be used within 12" [30cm] of a splice.

Model# MRHA7503 Shown



Telescoping Rail

Extends the reach beyond the working limits of the bridge.

Model# MRES7522 Shown



Air Tractors

Provides mobility to a load or fixture. Additionally, the load or fixture can be conveyed to the next position or returned home automatically. Capacity up to 3000 lbs [1360kg]. Mini tractor has a capacity up to 200 lbs.[90kg].

Model# TRA4000 Shown



Transfer Switch

Allows fixtures to be transferred between work zones without the need of cranes, fork trucks or disassembling the system.



Load Trolleys

Trolley Options:

- Boss Trolley
- Yoke Trolley
- Eye-hook Trolley
- Balancer Trolley.

Model# MRTA7006 Shown



End Trucks

Available in a variety of configurations. Choice depends on size, profile and loading condition of runway and bridge. Dual trolleys used when loads exceed 1000lbs [453kg], not to exceed 3000 lbs[1360kg].

Model# MRES7717 Shown

(Rail Accessories Continued)



Same Plane End Truck

Positions the bridge between the runway, which decreases the overall system vertical stack-up.

Model# MRES4028 Shown

Rigid End Truck

Eliminates bridge skew for applications that require added stability.

Model# MRES4226 Shown



Rod and Ball Hanger

Used for direct loads such as hoists or balancers.

Model# MRHS4036 Shown

Rigid Hanger

Adjustable I-beam hangers used for kick up loads such as arms or offset loads.

Model# MRHS4038 Shown



C-Channel Rod and Ball Hanger

Hanger with threaded rod leveling adjustments used for direct loads such as hoists or balancers.

Model# MRHS4034 Shown

C-Channel Bolt-On Hanger

Non-Adjustable hanger used for cantilevered or direct loads.

Model# MRHA4035 Shown



Knight Engineering Standards

All products have undergone rigorous testing prior to being added to the Knight Product Line.

All Knight Industries' Rail Systems are designed using proprietary copyrighted algorithms created specifically around the physical characteristics unique to our rail. These programs take into account material safety factor, working stress design factors as well as ultimate live load to yielding of material, calculated live load deflections, maximum bending stress, shear stress, etc. to ensure the optimum functionality and safety.

Knight Industries follows Material Handling Industry Standards in determining the capacity ratings for enclosed track overhead rail systems. Each component (e.g. rail, hangers, trolleys, etc.) is individually tested to establish its ultimate failure point. From this number, a safe working load (based on a 5:1 safety factor) is then assigned to the component. Each rail span length is then tested to determine the maximum single point load required to achieve a predetermined deflection based on a 1:350 ratio (1" of deflection for each 350" of length). The recommended rated capacity chart is based upon single point loading for the listed spans. The maximum of 3000 lbs. is a function of the 5:1 safety factor for the component with the lowest tested failure point.

Balancers

Air Balancers transfer and position loads via a unique float mode state. Due to the compressibility of the air, positioning of the load is possible with or without using an Up/Down pendant control. Designed to be used with the entire Knight product line as well as a variety of other manufacturers' products. All balancer capacities are rated at 100 psi.

Cable Balancers



Balancers come equipped with a safety retract control mechanism. Cable Balancers have a balancing capacity up to 700lbs[318kg] and are available with a maximum travel distance of up to 110" [279cm].

Model# KBA350-073 Shown

Chain Balancers



Designed for applications that are subject to excessive amounts of yarding, twisting or bouncing. Chain balancers have a balancing capacity up to 700lbs [318kg] and are available with a maximum travel distance of up to 80" [203cm].

Model# KBC350-067 Shown

Reeved Balancer



The balance capacity can be doubled by reeving. Reeved Balancers have a balancing capacity up to 1400lbs[635kg] and are available with a maximum travel distance of up to 55"[138cm].

Model# RKBA700-036 Shown

Dual Drum Balancer

Having two synchronized spools inside one housing, the dual drum offers added balance to awkwardly weighted or shaped loads.

Balancing from two suspension points, Dual Drum Balancers have a balancing capacity up to 700lbs [318kg] and are available with a maximum travel distance of up to 110" [279cm].

Model# DKBA350-073 Shown



Tandem Balancer



Doubles the load capacity of a single balancer without sacrificing vertical travel. Tandem Balancers have a balancing capacity up to 1400lbs [635kg] and are available with a maximum travel distance of up to 110" [279cm].

Model# TKBA700-073 Shown





Tandem Reeved Balancer

Handles loads up to four times heavier than the largest single or chain balancers. Tandem Reeved Balancers have a balance capacity up to 2800lbs [1270kg] and are available with a maximum travel distance of up to 55" [138cm].

Model# TRKBA700-036 Shown



Pneumatic Balancer Controls

Up/Down Pendant	Tandem Units Up/Down Pendant	High Relieving Single Balance
 <p>Variable speed control for loading and unloading varying weights. The most commonly used control for balancers. Available in straight or coiled hose and comes in standard lengths of 10'ft [3m]. Model# BCS3017 Shown</p>	 <p>Variable speed control used on Tandem balancers for loading and unloading varying weights. Available in straight or coiled hose and comes in standard lengths of 10'ft [3m]. Model# BCS3230 Shown</p>	 <p>Supports a constant weight at zero gravity. Used for near capacity or heavy weight applications greater than 150 lbs [68 kg]. Available in straight or coiled hose and comes in standard lengths of 10'ft [3m]. Model# BCS2090 Shown</p>
Feather Touch Balance	Single Balance	Dual Balance
 <p>Typically used for light weight applications. This control is activated by an up or down movement of the control handle. Available in straight or coiled hose and comes in standard lengths of 10'ft [3m]. Model# BCS2214 Shown</p>	 <p>Supports a constant weight at zero gravity. Recommended for applications where the part weight is less than 150 lbs [68kg]. Model# BCS2018 Shown</p>	 <p>Supports two different weights at zero gravity. Used in applications where the part weight does not change. Available in straight or coiled hose and comes in standard lengths of 10'ft [3m]. Model# BCS2215 Shown</p>

Balancer Accessories

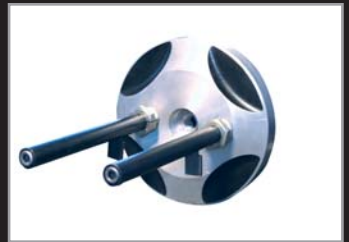

Balancer Limit Switch

Ability to set upper and lower limits. Eliminates unnecessary movements.

Model# BPA2224 Shown



External Retract Control

Hydraulic shocks provide continuous resistance to spool travel. Prevents spool from accelerating if a load is lost.

Model# BPA2089 Shown



Load Trolley

Used to attach balancers to various types of rail systems or I-beam.

Model# MRTA7705 Shown



Top Mount Single Hook

Used to attach a balancer by use of an eye-hook.

Model# BPA2016 Shown

Ergo Assists

Knight Ergo Assists accurately and effortlessly transfer materials of varying weights, shapes and sizes. Combined with an end-of-arm tooling, an operator can perform a variety of material handling applications.



Articulating Arms

The standard Articulating Arms are available in various sizes. Light duty arms are typically used for suspending single or multiple spindle torque tools. Medium duty arms are low profile by design and are ideal for limited space overhead applications. Applications with larger and/or heavier loads are ideal for heavy duty arms. The arms have a maximum weight capacity up to 500lbs[226kg] and may be either pedestal mounted or suspended from a rail system. Available with a maximum reach up to 96" [244cm] and a maximum travel distance up to 60".[152cm]

Model# AAA6000 Shown

Extension Arms

Extension Arms offer versatility by enabling the operator to extend beyond the working limits of a rail system. A Knight Balancer or Servo Hoist mounted on the extension arm lifts and lowers the load. Extension arms are available in either Single or Dual bridge configurations. Arms have a maximum weight capacity up to 700 lbs[317kg], maximum reach is adjustable up to 60"[152cm] and maximum travel distance up to 110"[275cm].

Model# JDA300073 Shown

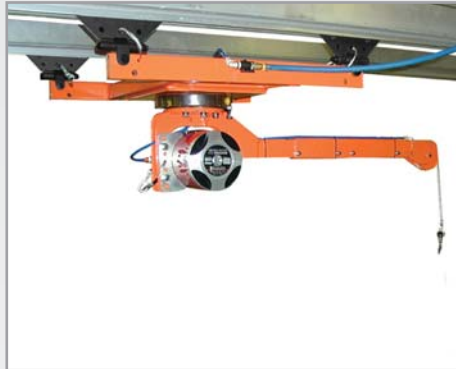

Path Guided Arms

Path Guided Arms guide the fixture through a predefined path. Ideal when part alignment is crucial. Available options include a clutch assembly that locks rotation on the arm while not in use or as required during operation.

Carriage Arms

Carriage Arms place the body of the arm between the runway saving up to 36" [91cm] of head room. Ideal for heavy offset loads up to 400lbs[181kg] in parallel with the running rails.

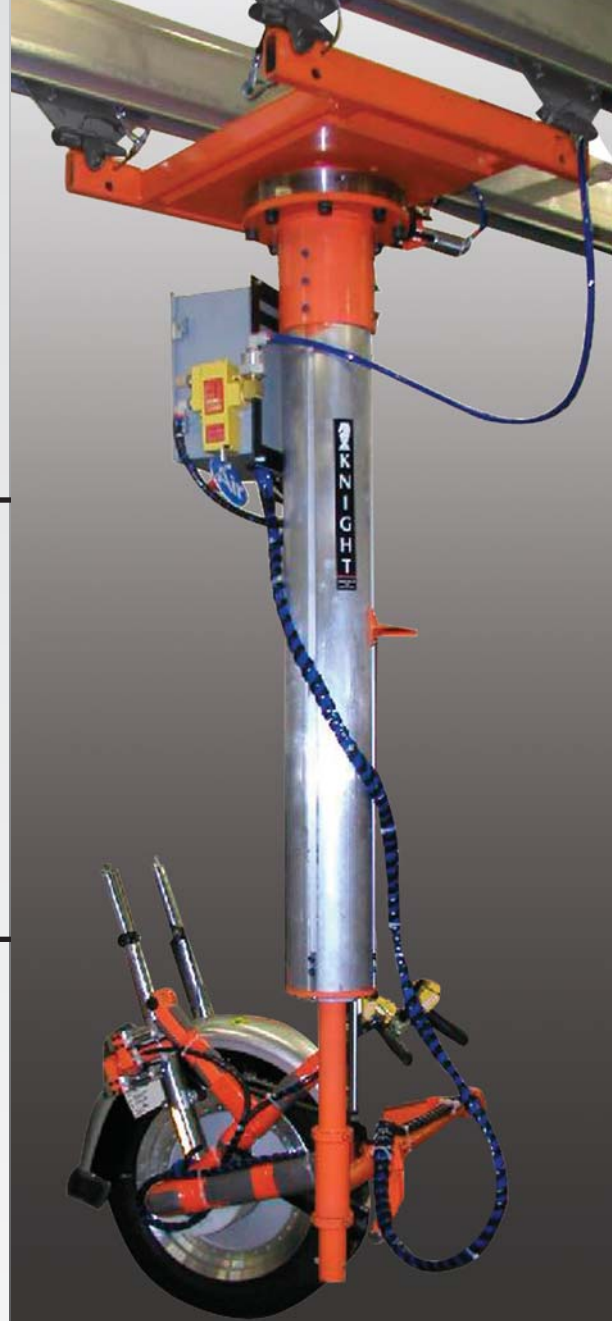

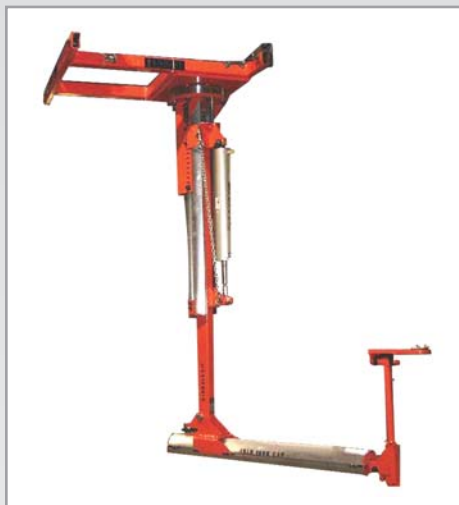

Vertical Mast Arms

The Vertical Mast Arm allows for end tooling to be mounted to a rigid vertical beam. Vertical travel is achieved by a Knight Balancer, Knight Servo Hoist, air cylinder, hydraulic cylinder, or chain hoist. Maximum capacity is based upon the maximum capacity of hoist being used. Maximum travel distance is dependent upon the hoist being used.

Model# VBA2000 Shown



Torque Pak

Torque Paks are designed to absorb torque reaction from fastening devices and balance the tool. Standard travel distance for the Torque Paks are 19" [48cm]. Custom Paks can Torque up to 442ft./lbs [600Nm]. Torque paks include a standard fixed tool holder. Custom travel distances, heights and tool holders are available.

Model# ATA2500 Shown

360° Rotating Clamp Style



Adjustable Clamp Style



The 360° rotary tool holder clamp is available in diameter sizes up to 2.5" [6.35cm]. Holder is adjustable for vertical or horizontal tool orientations.



Side Mounted Arm

Side Mounted Arms are pivot mounted which is optimal for small tools. Includes a standard tool holder. The standard arm has an available balance capacity up to 150lbs [68kg], maximum available reach up to 6' [1.8m] and maximum travel distance up to 32" [81cm]. (Shown in use with a LRD9500 Rail System)

Model# AAA3000 Shown

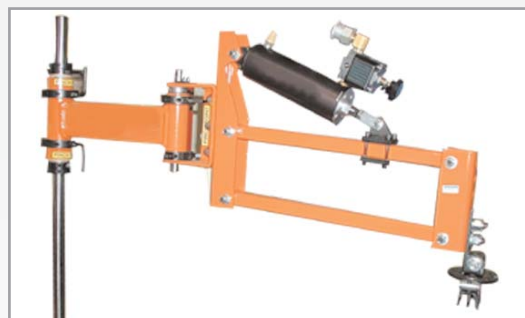

Tool Bench Arm

Tool Bench Arms work well on small part assembly applications. Includes a standard tool holder. The standard arm has an available balance capacity up to 25lbs [11kg]. The design of the arm allows it to absorb torque reaction from fastening devices and balance the tool. The maximum available travel distance is 13" [33cm].

Model# ABA2000 Shown



Single Cup Vacuum

Single cup vacuum fixture suspended by a Knight Servo Hoist transfers the torque converter to the transmission.



Multiple Vacuum Cup

Four (4) cup vacuum end effector with 90° rotate to transfer hood from rack to weld fixture.



I.D. Clamp Style

I.D. Clamp style fixture with adjustable centers that transfers the wheels from dunnage to conveyor.



J-Hook

Dual J-hook fixture suspended by a Knight balancer transfers the axle from dunnage to a conveyor.



Clamp Style

Clamp style fixture suspended from a Knight Articulating Arm that loads the HVAC system to the vehicle.

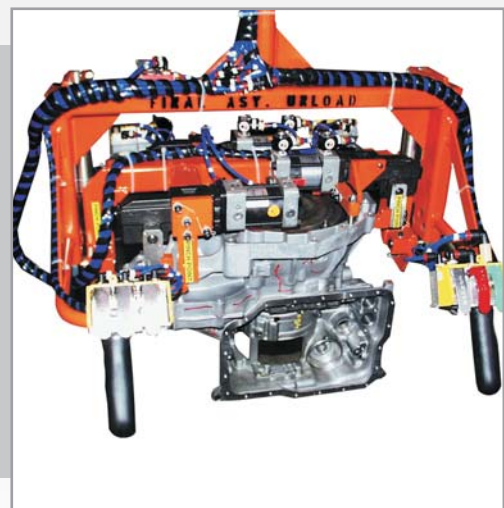

Clamp Style

Clamp style fixture with 90° rotate to transfer the transmission to assembly station.



Clamp Style

Transfers battery from the pallet to the vehicle on the assembly line.



Clamp Style

Clamp style fixture to load front end module to vehicle suspended by a Knight balancer mounted to an overhead extension arm .

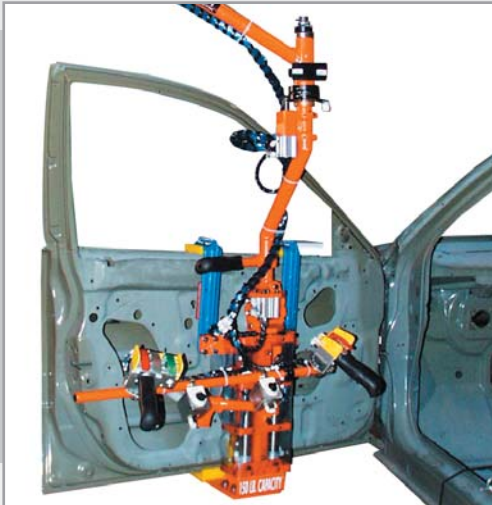

Clamp Style

Clamp style fixture removes the door from the vehicle.



Clamp Style

Clamp style fixture to load the instrument panel inside the vehicle.

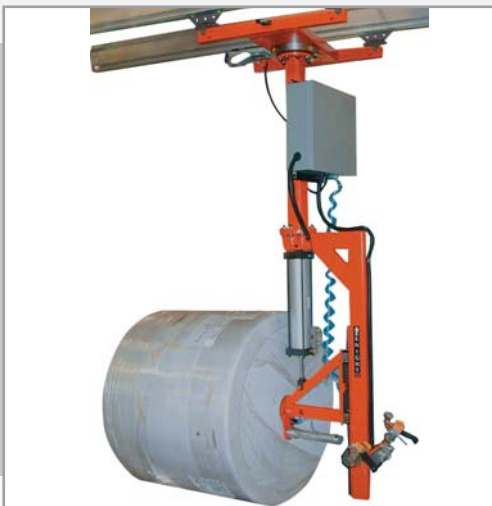

Core Style

Knight Vertical Arm with core style gripper and power push-off for transferring rolls of plastic film.



Clamp Style

Clamp style fixture with 45° rotate to transfer the seat to the assembly station.

Controls

Knight Control Handles include of one or more valve blocks and/or microswitches combined with an ergonomically specified handle. Control handle levers are marked according to customer specifications. Hose fittings and/or cables are supplied at the customer's request and specifications.

Pneumatic Control Handles



One (1) Button
Model# BPA9400 Shown



Two (2) Button
Model# BPA9100 Shown



Three (3) Button
Model# BPA9430 Shown



Four (4) Button
Model# BPA9310 Shown

Electrical Control Handles



One (1) Button
Model# EPA9201 Shown



Two (2) Button
Model# EPA9202 Shown



Three (3) Button
Model# EPA9203 Shown



Four (4) Button
Model# EPA9205 Shown

Lever Options



CUSTOMIZING LEVERS

The levers can be customized for identification and ease of use. Callouts are stamped out and available in different languages.

PAINT COLORS

Up (Green) and Down (Red) levers are our standard painted colors. Custom colors can be applied according to customer specification.

ANGLED LEVERS

Control handle levers can be angled to compensate for optimum ergonomics.

Tables, Carts and Shuttles

Knight Tables raise, tilt, slide, and rotate loads to proper ergonomic heights. Available Load Sensors maintain working height during varying weight loads. Tables are available in standard or custom sizes. Standard tables have a lifting capacity up to 8000lbs[3629kg], typical platform sizes up to 62"[157.5cm] x 96"[243cm] and collapsible heights down to 4"[10cm]. Custom tables are designed and built per customer specifications.



Lift

Lift Table raises loads to the proper ergonomic height for the operator. The table has a lifting capacity up to 8,000 lbs.[3629kg].

Model# L3636-2000 Shown



Lift and Rotate

Rotate Tables provides up to 360° rotation. The table has a lifting capacity up to 8,000 lbs.[3629kg].

Model# LR4860C-2000 Shown



Low Profile Lift

A collapsed height as low as 4"[10cm]. The table has a lifting capacity up to 6,000 lbs.[2722kg].

Model# LPL4353-6000 Shown



Low Profile Lift and Rotate

A collapsed height of nearly half our standard table and the ability to rotate loads. The table has a lifting capacity up to 6,000 lbs.[2722kg].

Model# LPLR4353-6000 Shown



Lift and Tilt

Combines lift and tilt functions. The table has a lifting capacity up to 6,000 lbs.[2722kg].

Model# LT4860-4000 Shown



Cart Lift

Table lifts a cart to an operators working level. The table has a lifting capacity up to 2,000 lbs.[907kg].

Customized per order

Tables, Carts and Shuttles



Tilt

By tilting the container forward, the table positions the dunnage for easy loading or unloading. The table has a lifting capacity up to 8,000 lbs.[3629kg].

Model# T4860-4000 Shown



Slide - Tilt

The slide-tilt table slides out of the way of the operator's working area. The table has a lifting capacity up to 8,000 lbs.[3629kg].

Model# ST5560-4000 Shown



Corner Tilt

Tilts load to a safe ergonomic height, positioning the pallet or basket to the operator's working level. The table has a lifting capacity up to 4,000 lbs.[1814kg].

Model# CT3636-4000 Shown



Turntables

Turntables can be supplied in single, two or four position configurations. Parts can be continuously supplied to an assembly station. The table has a capacity up to 8,000 lbs.[3629kg].

Model# Customized per order



Double Scissor Lift

When extra lift is needed to raise loads to a safe ergonomic height for the operator. The table has a lifting capacity up to 2,000 lbs.[907kg].

Model# DSL4860-1000 Shown



Push / Tugger Cart

Fork free carts in either push or tugger configurations when light capacity (up to 1500lbs. [680kg]) portability is required.

Push Cart with Rotate Option Shown



Small Footprint Zero Loader

Convenience of ground level loading with the footprint of a standard lift table. The table has a lifting capacity up to 4,000 lbs.[1814kg].

Model# Customized per order



Zero Loader

Ground level loading with a pallet jack when fork truck access is limited. The table has a lifting capacity up to 4,000 lbs.[1814kg].

Model# TZ4860-2000 Shown



Operator Platform Lift

Ergonomically positions the operator. The table has a lifting capacity up to 2,000 lbs.[907kg].

Model# N/A Customized per order



Smart Cart

The Smart Cart is ideal when portable powered material manipulation is required for the application. The cart has a capacity up to 400 lbs.[181kg].

Model# SCS435266 Shown

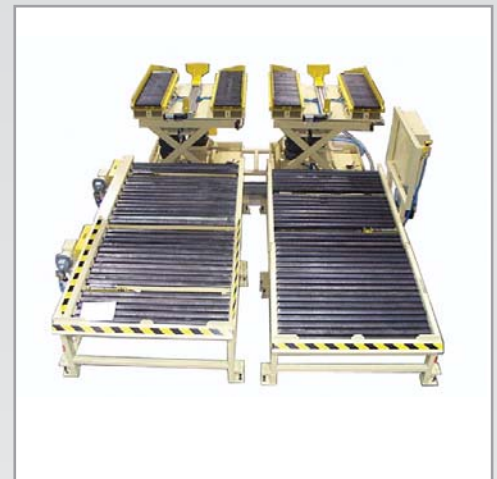

Shuttle Systems

Knight uses the highest operational efficiency in custom shuttles. The shuttles have a capacity up to 4,000 lbs.[1814kg].

Model# N/A Customized per order



Powered Accumulators

Transfers parts between two workstations and offers an accumulation of parts at the off-load end.

Model# N/A Customized per order

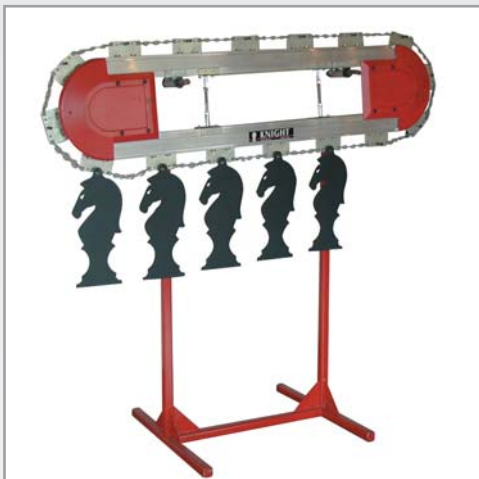

Non-Powered Accumulators

Transfer parts between workstations for assembly applications. No power source is required.

Model# N/A Customized per order



Small Footprint Over/under

Exclusive designs provide a shuttle system in a compact footprint. The shuttle has a lifting capacity up to 2,000 lbs.[907kg].

Model# N/A Customized per order

Table Accessories



Table Controls

Controls are available in either pedestal or foot controls.



Bellows Skirting

Protective covering that serves as a barrier for the operator and keeps debris from entering the table.

Model# BSS100T Shown



Motion Stabilizer

Motion stabilizers keep loads traveling upward and downward in a smooth, consistent manner.

Model# MSD-100 Shown



Steel Riser

All steel reinforced construction ensures a safe and sturdy mounting base at the customer's specified height.

Model# ASTR-100 Shown

The Knight Website



Visit our website @ www.knight-ind.com to obtain detailed information on product lines, videos, technical manuals, brochures and contact lists .

Knight Industries is known worldwide for:

- ▶ **Experience:** Designing and building specialty equipment since 1984.
- ▶ **Building Space:** Over 150,000 square feet
- ▶ **Distribution:** 60 Distributors Worldwide
- ▶ **Design:** State-of-the-Art 2D and 3D design software.
- ▶ **Quality Assurance:** Includes duty cycle and destructive testing capabilities.
- ▶ **Service:** Stand alone department, fully trained field service technicians.
- ▶ **Controls:** Electrical and pneumatic capabilities.
- ▶ **Build:** Full CNC , Laser/Plasma Cutting and Laser Welding technologies.
- ▶ **Support Staff:** Project Management, I.T. , Standards, Scheduling and Graphics.



Knight's Headquarters and Facilities in Auburn Hills, MI



09/06 Made With Pride In The USA



KNIGHT INDUSTRIES

1140 Centre Road
Auburn Hills, MI 48326 USA
Phone: (248) 377-4950
Fax: (248) 377-2135
www.knight-ind.com